

Measuring transducer for active or reactive power

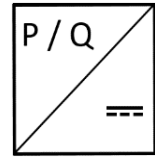

EW 4.0,
DGW 4.0, VGW 4.0,
DUW 4.0, VUW 4.0,
EB 4.0
DGB 4.0, VGB 4.0,
DUB 4.0, VUB 4.0

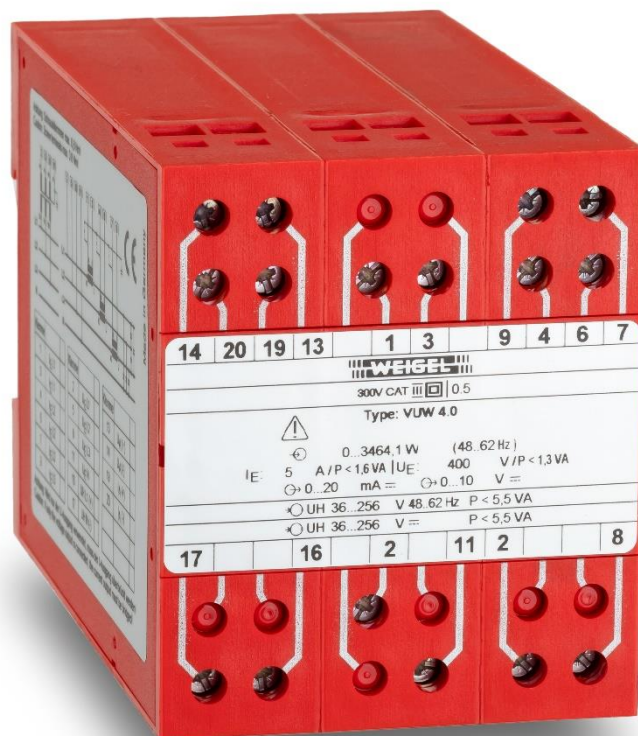

Application

The power measuring transducers of the 4.0 series in a compact design convert active or reactive power into an impressed direct current and an impressed direct voltage with the correct sign. These can then be displayed, registered and/or used for control at the measuring site or in measuring stations located further away.

The range of measuring transducers for active or reactive power includes types for single-phase alternating current networks (EW/EB) as well as for three- or four-wire three-phase networks with the same or any load (DGW/B, DUW/B or VGW/B, VUW/B).

Several evaluation devices (indicators, controllers, computers, etc.) can be connected simultaneously up to the maximum or minimum permissible load.

Power is supplied via a separate auxiliary power input. Input, output and the auxiliary voltage input are galvanically isolated from each other. The outputs are short-circuit-proof and idle-proof.

The measuring transducers are intended for installation in plants, devices or switchboards. The regulations regarding the construction of those electrical systems must be observed.

Working principle

Measuring transducers for active and reactive power work with an integrated analog multiplier. The two converters in the current and voltage path galvanically isolate the power circuits from the electronics and adapt the input current and input voltage to the multiplier, which multiplies the measured values analogously and integrates them with a low pass.

The real 3-phase recording of the current and voltage values ensures absolutely correct measurement results within the specified accuracy class in all operating states of the network.

For any load in three-phase networks, the product of voltage and current is formed by two or three multipliers.

An integrated voltage-current converter provides the output variables in the form of an impressed direct current and an impressed direct voltage.

Block circuit diagram

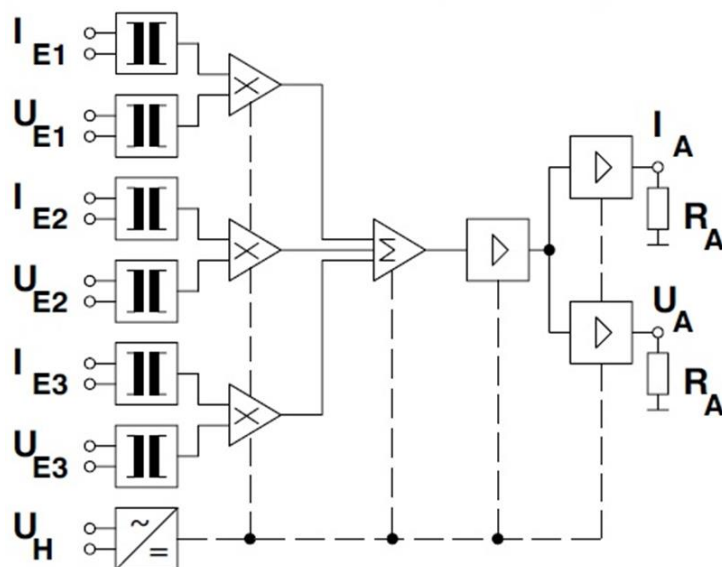

notice:

Input, outputs and auxiliary voltage are galvanically isolated from each other.

Connection diagrams

EW

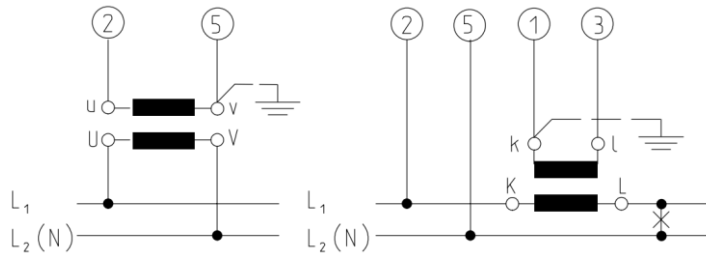

DGW

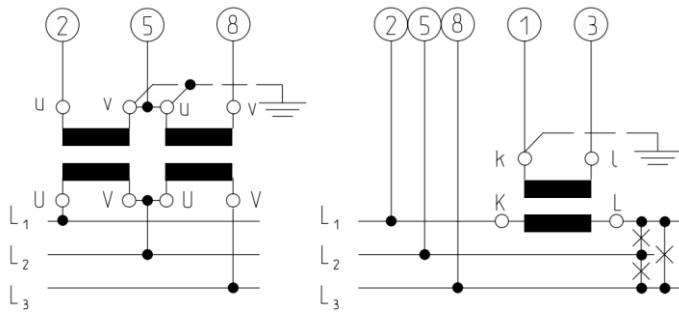

VGW

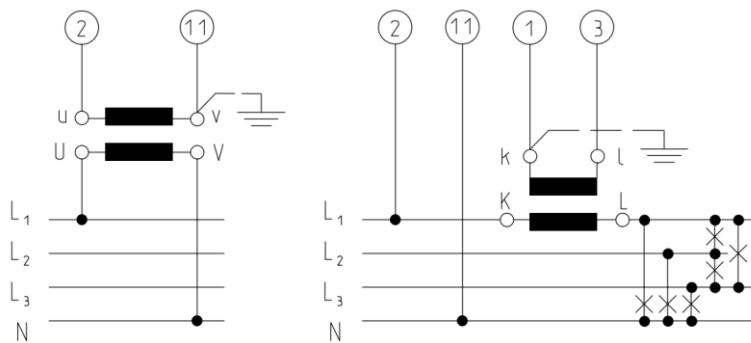

DUW

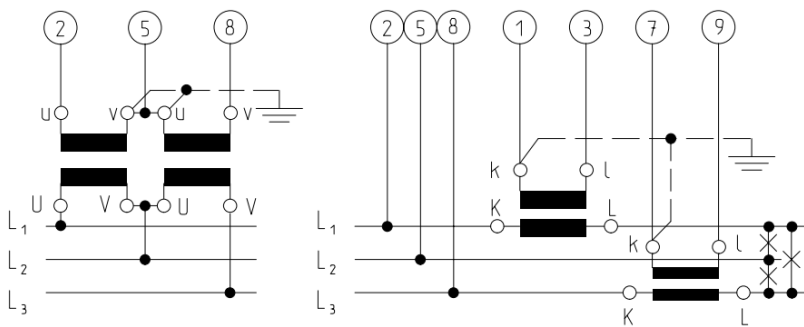

VUW

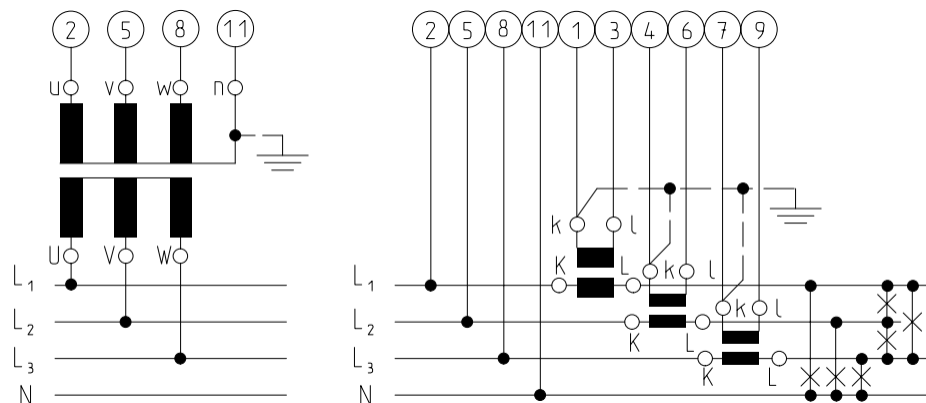

Connection diagrams

EB

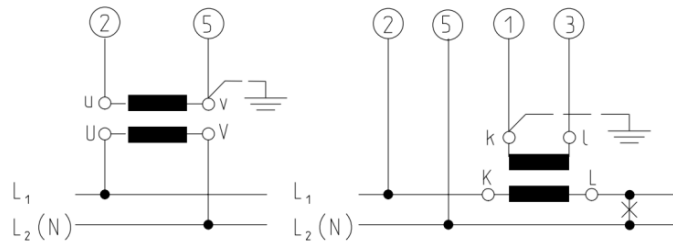

DGB

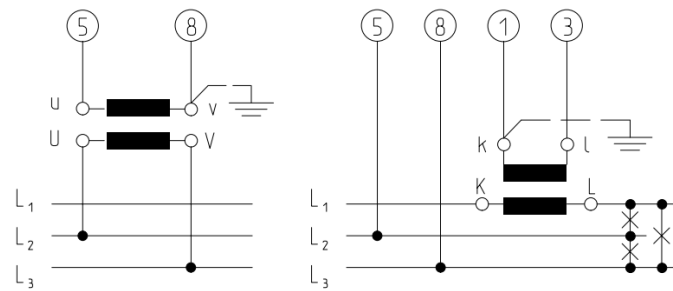

VGB

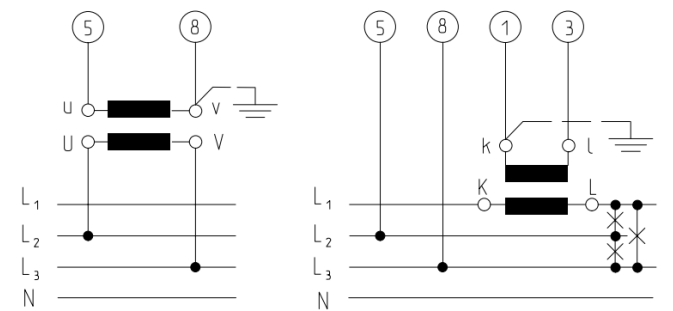

DUB

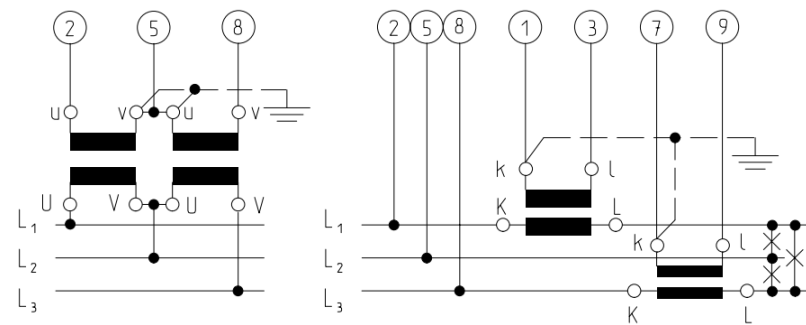

VUB

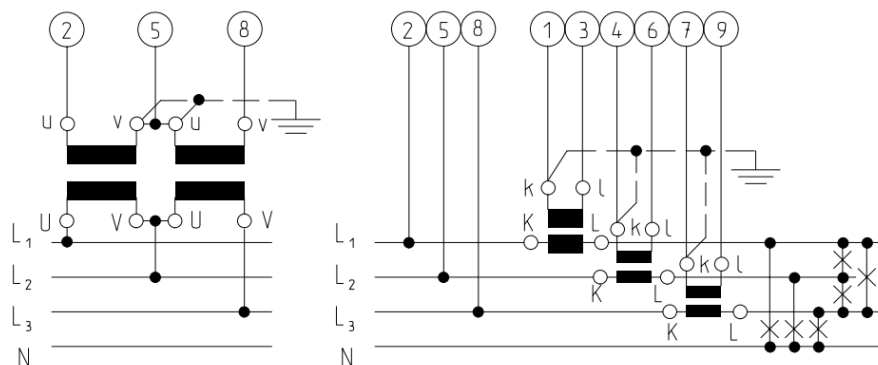

Inputs

Input quantity	Sinusoidal or non-sinusoidal AC current and AC voltage												
Measurable quantity PE	Active or Reactive power												
	<table border="0"> <tr> <td style="text-align: center;">Active power</td> <td style="text-align: center;">Reactive power</td> </tr> <tr> <td style="text-align: center;">EW</td> <td style="text-align: center;">EB</td> </tr> <tr> <td style="text-align: center;">DGW</td> <td style="text-align: center;">DGB</td> </tr> <tr> <td style="text-align: center;">VGW</td> <td style="text-align: center;">VGB</td> </tr> <tr> <td style="text-align: center;">DUW</td> <td style="text-align: center;">DUB</td> </tr> <tr> <td style="text-align: center;">VUW</td> <td style="text-align: center;">VUB</td> </tr> </table>	Active power	Reactive power	EW	EB	DGW	DGB	VGW	VGB	DUW	DUB	VUW	VUB
Active power	Reactive power												
EW	EB												
DGW	DGB												
VGW	VGB												
DUW	DUB												
VUW	VUB												
Single-phase AC network													
Three-wire three-phase system balanced load													
Four-wire three-phase system balanced load													
Three-wire three-phase system unbalanced load													
Four-wire three-phase system unbalanced load													
Measuring range	0 ... P _N or – P _N ... 0 ... P _N P _N = (0.3 ... 1.2) U x P _s												
The apparent power P _s results from the primary values of current and voltage transformers													
Single-phase AC network	P _S = U x I												
Three-phase network	P _S = √3 x U x I												
Rated input voltage U _{EN}	0 ... 50 ... 519 V												
Rated input current I _{EN}	0 ... 0.5 ... 5 A												
Operating voltage	max. 519 V												
Permissible control range	1.2 U _{EN} or 1.2 I _{EN}												
Overload limit	1.2 U _{EN} , 1.2 I _{EN} continuous 2 U _{EN} , 20 I _{EN} max. 1 s ≤ 5 A, 20 I _{EN} max. 1 s > 5 A, 12,5 I _{EN} max. 1 s												
Rated frequency range	45 ... 62 Hz total harmonic distortion ≤ 0,2 (all types, except EB) Type EB: 50 Hz <u>or</u> 60 Hz, total harmonic distortion ≤ 0,2												
Power consumption	approx. 1 mA per voltage path < 0.1 VA per current path at 1 A input < 0.4 VA per current path at 5 A input < 0.8 VA per current path at 8 A input												

Outputs

Current output

Output current I _A	impressed DC current
Rated current I _{AN}	0 ... 20 mA or 4 ... 20 mA
Burden area R _A	0 ... 10 V / I _{AN}
Current limitation	to approx. 37 mA

Voltage output

Output voltage U _A	impressed DC voltage
Rated voltage U _{AN}	0 ... 10 V or 2 ... 10 V
Burden R _A	≥ 4 kΩ
Burden error	≤ 0.1 % based on 50 % load change

Residual ripple	≤ 1 %eff
Setting time	approx. 500 ms
Open circuit voltage	≤ 15 V

Conversion characteristics

standard

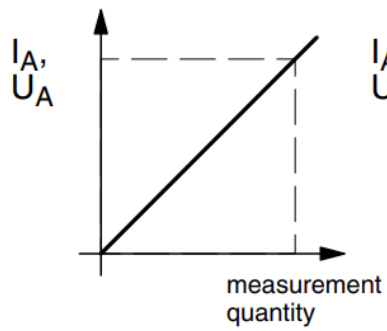

"live zero"

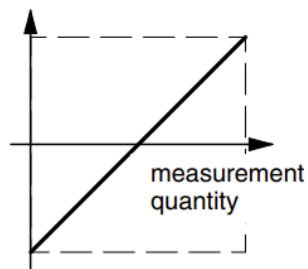
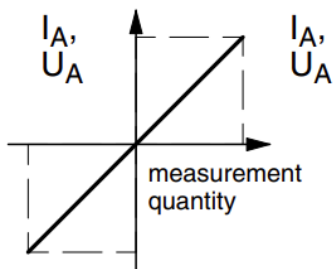
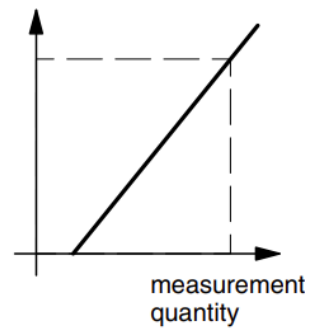
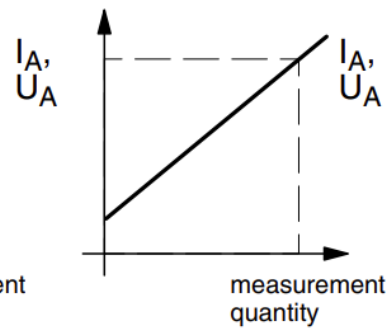

Auxiliary voltages

Auxiliary voltage

20 ... 100 V= or 20 ... 70 V~
36 ... 265 V= or 36 ... 265 V~

Power consumption

< 3 VA
< 6 VA

Terminal assignment

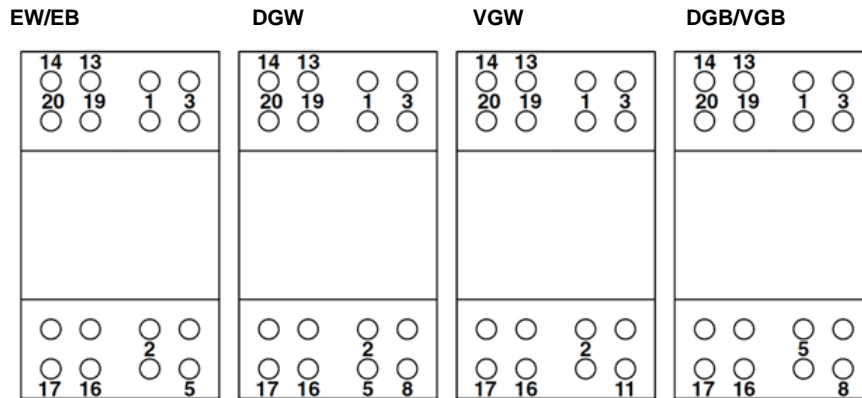

Clamp	EW/EB	DGW	VGW	DGB	VGB
1	I _E L ₁	I _E L ₁	I _E L ₁	I _E L ₁	I _E L ₁
2	U _E L ₁	U _E L ₁	U _E L ₁	–	–
3	I _E L ₁	I _E L ₁	I _E L ₁	I _E L ₁	I _E L ₁
5	U _E L ₂	U _E L ₂	–	U _E L ₂	U _E L ₂
8	–	U _E L ₃	–	U _E L ₃	U _E L ₃
11	–	–	U _E N	–	–
13	U _A (+)	U _A (+)	U _A (+)	U _A (+)	U _A (+)
14	U _A (–)	U _A (–)	U _A (–)	U _A (–)	U _A (–)
16	U _H L ₁ (+)	U _H L ₁ (+)	U _H L ₁ (+)	U _H L ₁ (+)	U _H L ₁ (+)
17	U _H N(–)	U _H N(–)	U _H N(–)	U _H N(–)	U _H N(–)
19	I _A (+)	I _A (+)	I _A (+)	I _A (+)	I _A (+)
20	I _A (–)	I _A (–)	I _A (–)	I _A (–)	I _A (–)

- U_E Voltage input
 The numbers on the terminals correspond to details in the
 Connection diagrams (according to DIN 43 807).
 I_A Current output
 U_A Voltage output
 U_H Auxiliary voltage input

Caution:

The two outputs must not be connected to each other!

If only the voltage output is connected, terminals 19 and 20 (current output) must be bridged!

Terminal assignment

DUW

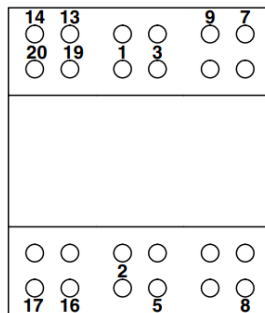

DUB

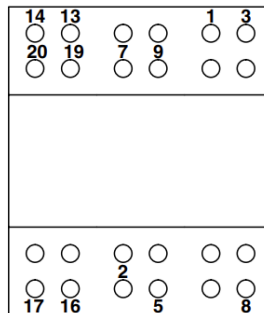

VUW

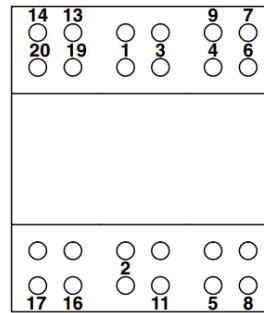

VUB

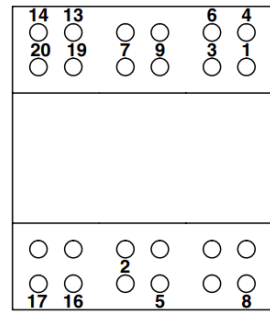

Clamp

	DUW	VUW	DUB	VUB
1	$I_E L_1$	$I_E L_1$	$I_E L_1$	$I_E L_1$
2	$U_E L_1$	$U_E L_1$	$U_E L_1$	$U_E L_1$
3	$I_E L_1$	$I_E L_1$	$I_E L_1$	$I_E L_1$
4	–	$I_E L_2$	–	$I_E L_2$
5	$U_E L_2$	$U_E L_2$	$U_E L_2$	$U_E L_2$
6	–	$I_E L_2$	–	$I_E L_2$
7	$I_E L_3$	$I_E L_3$	$I_E L_3$	$I_E L_3$
8	$U_E L_3$	$U_E L_3$	$U_E L_3$	$U_E L_3$
9	$I_E L_3$	$I_E L_3$	$I_E L_3$	$I_E L_3$
11	–	$U_E N$	–	–
13	$U_A(+)$	$U_A(+)$	$U_A(+)$	$U_A(+)$
14	$U_A(-)$	$U_A(-)$	$U_A(-)$	$U_A(-)$
16	$U_H L_1 (+)$	$U_H L_1 (+)$	$U_H L_1 (+)$	$U_H L_1 (+)$
17	$U_H N (-)$	$U_H N (-)$	$U_H N (-)$	$U_H N (-)$
19	$I_A (+)$	$I_A (+)$	$I_A (+)$	$I_A (+)$
20	$I_A (-)$	$I_A (-)$	$I_A (-)$	$I_A (-)$

I_E Current input
 U_E Voltage input
 The numbers on the terminals correspond to details in the Connection diagrams (according to DIN 43 807).
 I_A Current output
 U_A Voltage output
 U_H Auxiliary voltage input

Caution:

The two outputs must not be connected to each other!

If only the voltage output is connected, terminals 19 and 20 (current output) must be bridged!

Preference types:

The table below lists standard measuring ranges for voltages of 230/400 V and current ratings N/1 A or N/5 A.

IEN (A)		EW/EB	PEN (kW)	DGW/B VGW/B DUW/B VUW/B
		Calibration factor 0.87		Calibration factor 0.72
directly 1	1/5	0.2		0.5
5/1	directly 5	1		2.5
10/1	10/5	2		5
15/1	15/5	3		7.5
20/1	20/5	4		10
25/1	25/5	5		12.5
30/1	30/5	6		15
40/1	40/5	8		20
50/1	50/5	10		25
60/1	60/5	12		30
75/1	75/5	15		37.5
80/1	80/5	16		40
100/1	100/5	20		50
120/1	120/5	24		60
150/1	150/5	30		75
200/1	200/5	40		100
250/1	250/5	50		125
300/1	300/5	60		150
400/1	400/5	80		200
500/1	500/5	100		250
600/1	600/5	120		300
750/1	750/5	150		375
800/1	800/5	160		400
1000/1	1000/5	200		500
and decadal Multiples	and decadal Multiples	and decadal Multiples		and decadal Multiples

Types in this preferred series offer advantages for the user in that they are calibrated to the same secondary value (calibration factor 0.87 or 0.72).

This means that they are interchangeable within the listed converter connection values and the resulting performance; recalibration is not necessary. However, the nameplate should be changed.

Example:

A system with 230/400 V and a current transformer of 250 A, a power output of 125 kW is calculated for a VUW measuring transducer.

The apparent power ($\cos = 1$) for this network would be:

$$P_s = U \cdot I \cdot \sqrt{3} \cdot \cos \varphi$$

$$P_s = 400 \text{ V} \cdot 250 \text{ A} \cdot \sqrt{3} \cdot 1$$

$$P_s = 173 \text{ kW}$$

multiplied by a calibration factor of 0.72 results in $P_{EN} = 125 \text{ kW}$ (see table).

If the current transformer connection is changed to 400 A, for example, the power is calculated as follows:

$$P_{EN} = U \cdot I \cdot \sqrt{3} \cdot 0.72$$

$$P_{EN} = 400 \text{ V} \cdot 400 \text{ A} \cdot \sqrt{3} \cdot 0.72$$

$$P_{EN} = 200 \text{ kW (see table)}$$

General technical data

Case design	Surface-mounted housing for snap mounting on DIN rail TH 35 according to DIN EN 60 715	
Case material	ABS/PC black self-extinguishing according to UL 94 V-0	
Connections	Screw terminals	
Wire cross section	max. 4mm ²	
Protection class	IP 40 housing IP 20 terminals	
Test voltages	All circuits against housing: 3510 Vrms 5 sec Measuring circuit and auxiliary voltage against output: 3510 Veff 5 sec Currents against each other and against voltages: 3510 Veff 5 sec	
Operating voltage	300 V (rated voltage phase-zero)	
Protection class	II	
Measurement category	CAT III	
Pollution level	2	
Dimensions	EW EB VGW VGB DGW DGB 45mm x 80mm x 115mm	DUW DUB VUW VUB 67.5mm x 80mm x 115mm
Weights:	EW EB VGW VGB DGW DGB approx. 0.25 kg	DUW DUB VUW VUB approx. 0.43 kg

Accuracy at reference conditions

Accuracy class	0.5 (± 0.5 % of end value)
Temperature drift	≤ 0.02 %/K, valid for standard version and max. 1 year

Reference conditions

Input voltage	UEN ± 2 %
Power factor	Active power cos φ = 1.0 to 0.8 ; Reactive power sin φ = 1.0 to 0.8
Frequency	45 ... 62 Hz ± 1 %, harmonic content 0.05 (except type EB: only 50 Hz <u>or</u> 60 Hz)
Auxiliary voltage	UHN ± 2 %, 50 ... 60 Hz
Ambient temperature	23 °C ± 1 K
Warm-up time	≤ 5 mins

Environmental conditions

User group I	Transducer class K55
Operating temperature range	-20 ... +55 °C
Storage temperature range	-25 ... +70 °C
Relative humidity	≤ 75 % annual average, none condensation, only indoor use

Ordering guide

Order number	Measuring transducer for active or reactive power series 4.0
	Active power
PMU10-1	EW 4.0 single-phase AC network
PMU11-1	DGW 4.0 three-wire three-phase network with the same load
PMU12-1	DUW 4.0 three-wire three-phase network of any load
PMU13-1	VGW 4.0 four-wire three-phase network with the same load
PMU14-1	VUW 4.0 four-wire three-phase network of any load
	Reactive power
PMU19-1	EB 4.0 single-phase AC network
PMU15-1	DGB 4.0 three-wire three-phase network with the same load
PMU16-1	DUB 4.0 three-wire three-phase network of any load
PMU17-1	VGB 4.0 four-wire three-phase network with the same load
PMU18-1	VUB 4.0 four-wire three-phase network of any load
	Current input (if used specify primary values)
1	1 A
5	5 A
9	special current input up to max. 8 A
	Voltage input (if used specify primary values)
1	57,5 V
2	63,5 V
3	100 V
4	110 V
5	115 V
6	120 V
7	230 V
8	240 V
9	special voltage input
A	380 V (max. 300 V nominal mains voltage phase-zero)
B	400 V (max. 300 V nominal mains voltage phase-zero)
C	415 V (max. 300 V nominal mains voltage phase-zero)
D	440 V (max. 300 V nominal mains voltage phase-zero)
E	500 V (max. 300 V nominal mains voltage phase-zero)
	Measuring ranges
1	as specified
	Frequency range input
2	48...62 Hz (all types except EB)
9	special frequency
A	50 Hz (only EB)
B	60 Hz (only EB)
	Output
1	0...20 mA and 0...10 V
2	0...10 mA and 0...10 V
3	0...5 mA and 0...10 V
4	4...20 mA and 2...10 V
5	-20...0...20 mA and -10...0...10 V
9	special output
	Auxiliary supply
4	DC 20...100 V / AC 20...70 V
5	DC 36...265 V / AC 36...265 V
	Manufacturing certificate
0	without
1	with

Guidelines and standards

Directive 2014/30/EU	EMC Directive
Directive 2014/35/EU	Low Voltage Directive
Directive 2011/65/EU	RoHS Directive
DIN EN 60529	Protection types through housing
DIN EN 60688	measuring transducer for converting alternating current variables into analog or digital signals
DIN EN 60715	Dimensions of low-voltage switching devices
	Standardized mounting rails for the mechanical fastening of electrical devices in switchgear
DIN EN 61010-1	Safety regulations for electrical measuring, control, regulation and laboratory devices
	Part 1: General requirements
DIN EN 61326-1	Electrical measuring, control, regulating and laboratory devices - EMC requirements -
	Part 1: General requirements
	61000-4-3 Evaluation criterion B

Safety regulations and general information



- Check the relevant details for installation of the Measuring transducer against the nameplate and the terminal connections to ensure that they are suitable for your area of application.
- The Measuring transducer may only be installed by qualified electricians.
- The Measuring transducer must be checked for transport damage before commissioning and may only be put into operation if it is in perfect condition. In case of safety-relevant damages the Measuring transducer may not be put into operation.



- Ensure that the connections match the terminal connections.
- Circuits must be fused for the maximum permissible currents.
- When commissioning and using the Measuring transducer, the applicable laws, regulations and provisions for the respective area of use and application must be observed.
- The Measuring transducer is not suitable for use in environments with explosive gases or explosive substances.
- The Measuring transducer may only be operated in the environmental and ambient conditions specified in the data sheet. Direct sunlight must be avoided.
- The Measuring transducer may only be installed on non-flammable materials. The applicable fire protection regulations in the area of use and application must be observed.



- Due to the operating voltage, the distance or insulation from other devices must be observed in accordance with the applicable regulations.
- Stranded cables are only permitted if they are fitted with wire end sleeves.
- Connecting cables must be laid away from electromagnetic interference fields.
- Dangerous electrical voltage (more than 75 V DC or more than 50 V AC) can lead to electric shock and burns.
- The Measuring transducer must always be disconnected when fitting, removing, installing, uninstalling or troubleshooting.



- The Measuring transducer is maintenance-free when used as intended.
- Improper use and non-compliance with these safety instructions can lead to serious injury or even death.

Weigel Meßgeräte GmbH

Am Farnbach 4a
D-90556 Cadolzburg

Phone: +49 9103 / 62694-0
www.weigel-messgeraete.de
info@weigel-messgeraete.de

Technical changes reserved
(12/2024)